

PREVENTIVE MAINTENANCE

The maintenance package offered by EMA Indutec for your machine includes a machine inspection and basic maintenance with the following scope:

Machine:

- Checking the machine cover for damage
- Checking the safety devices
- Checking the sleeves and carriages for function and play
- Checking the hoses for damage and leaks
- Checking the function of the limit switches (readjustment of the switches if necessary)
- Lubrication of all lubrication points, if there is no central lubrication system
- Checking the central lubrication system, if installed
- Functional check of the flow sensors
- Inspection and cleaning of the laser scanning, if installed
- Inspection and cleaning of the pyrometer, if installed
- Measurement of the function-relevant machine geometry
- Replacement of the toothed belts

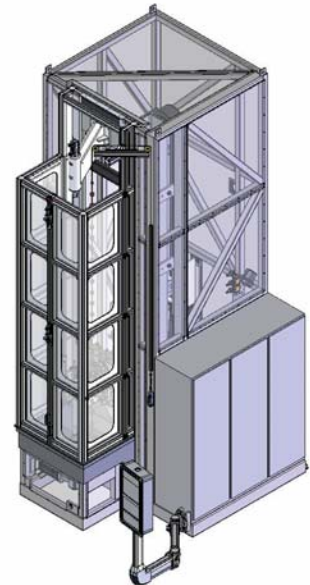

Inductor and quench:

- Checking the splash pattern of the quenches
- Visual inspection for damage to the inductor
- Replacement of the O-rings on the inductor

Energy transmission:

- Visual inspection of the transformers
- Inspection of the intermediate jaws with replacement of the O-rings
- Checking for leaks at the connection between the machine and the converter
- Checking the connection heads of the coaxial cable
- Checking the intermediate jaws for leaks

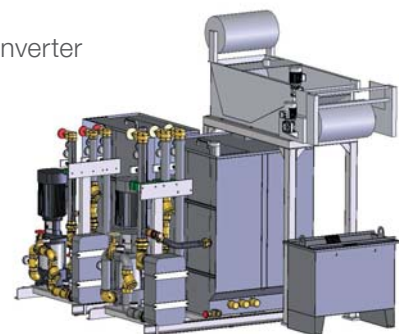

Recooling plant:

- Functional checking of valves and manometers
- Functional testing of the safety valve
- Checking the heat exchanger for contamination
- Cleaning of the dirt traps with replacement of filter elements
- At the customer's request, and with a separate invoice, the water can be analyzed externally.

Advantages of a service agreement with EMA Indutec:

- Best possible technical condition of your systems due to close collaboration between the system operator and the manufacturer
- Inspection and testing of the feeding systems, machines, converters and peripheral devices
- Consistent reduction of the causes of damage as well as component optimization to increase operating reliability and performance
- Optimal functionality of the system and therefore higher availability and reduced operating costs.